

CODE	N° OF PLATES	H
17B2071004	10	30
17B2071204	12	35
17B2071404	14	39
17B2071604	16	44
17B2071804	18	48
17B2072004	20	53
17B2072204	22	58
17B2072404	24	62
17B2072604	26	67
17B2072804	28	71
17B2073004	30	76
17B2073204	32	81
17B2073404	34	85
17B2073604	36	90
17B2074004	40	99
17B2074204	42	104
17B2074604	46	113
17B2075004	50	122

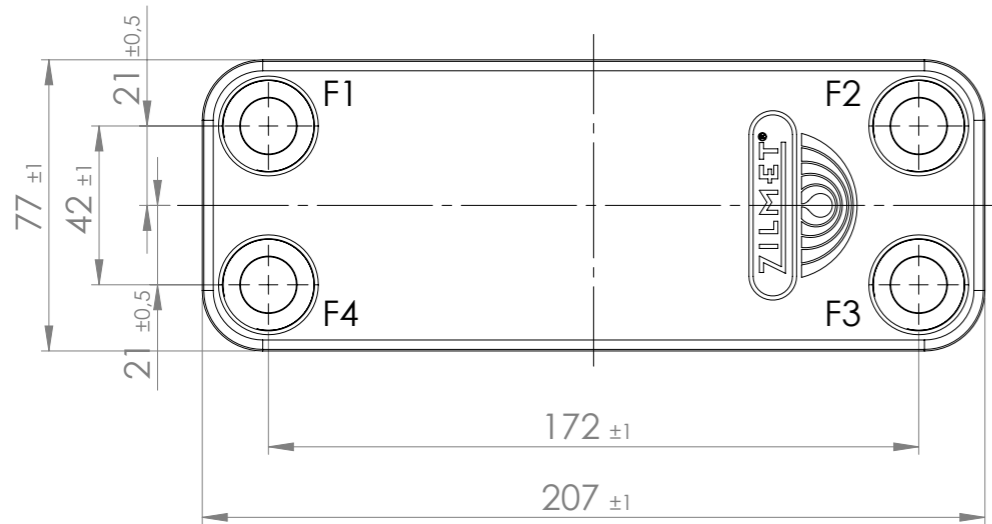

CIRCOLAZIONE FLUIDI CIRCUITO PRIMARIO F1 - F2 (PRIMARY CIRCUIT F1 - F2)
 CIRCUITO SECONDARIO F3 - F4 (SECONDARY CIRCUIT SANITARY F3 - F4)

Press.max eserc. circ. primario (Max oper. press. primary circuit): 5 bar
 Press.max eserc. circ. second. (Max oper. press. second. circuit): 10 bar
 Temperatura esercizio (Max oper. temperature): -10/+120 °C
 Materiale piastre corr. (Shaped plates material): INOX AISI 316L
 Materiale di brasatura (Brazing material): 99.9% Cu
 Materiale raccordi (Connection material): INOX AISI 316

DRAWING FOR APPROVAL
 PLEASE RETURN THIS DRAWING WITH
 YOUR COMPANY STAMP, SIGNATURE AND
 DATE. AFTER YOUR APPROVAL WE WILL
 BE PROCEEDING WITH SUPPLIES AND
 PRODUCTION.

Revisioni		
Rev.	Descrizione	Data
08	REDESIGNED WITH S.W.	14/05/2013
09	Rotated the logo; F1, F2, F3, F4	27/08/2018

Zilmet S.p.a. Via del Santo, 242 35010 Limena (PD)-ITALY Tel. +39 049 7664901 Fax +39 049 767321 www.zilmet.com zilmet@zilmet.it	DRAWING N°	SCALE	MATERIAL
	ZB 207	1:2	SEE TABLE
DENOMINATION	DRAWN	DATE	SIGNATURE
BRAZED HEAT EXCHANGER	BALDO A.	27/08/2018	<i>[Signature]</i>
	CHECKED	DATE	SIGNATURE
	PIROVANO M.	27/08/2018	<i>[Signature]</i>
	APPROVED	DATE	SIGNATURE
	Sig.ri BENETTOLO	27/08/2018	<i>[Signature]</i>
			CODE
			17B207--04
			Dimensions in mm
			This drawing is the property of company Zilmet S.p.a. All rights reserved.
			A3