

CODE	N° OF PLATES	H
17B2071002	10	30
17B2071202	12	35
17B2071402	14	39
17B2071602	16	44
17B2071802	18	48
17B2072002	20	53
17B2072202	22	58
17B2072402	24	62
17B2072602	26	67
17B2072802	28	71
17B2073002	30	76
17B2073202	32	81
17B2073402	34	85
17B2073602	36	90
17B2074002	40	99
17B2074202	42	104
17B2074602	46	113
17B2075002	50	122

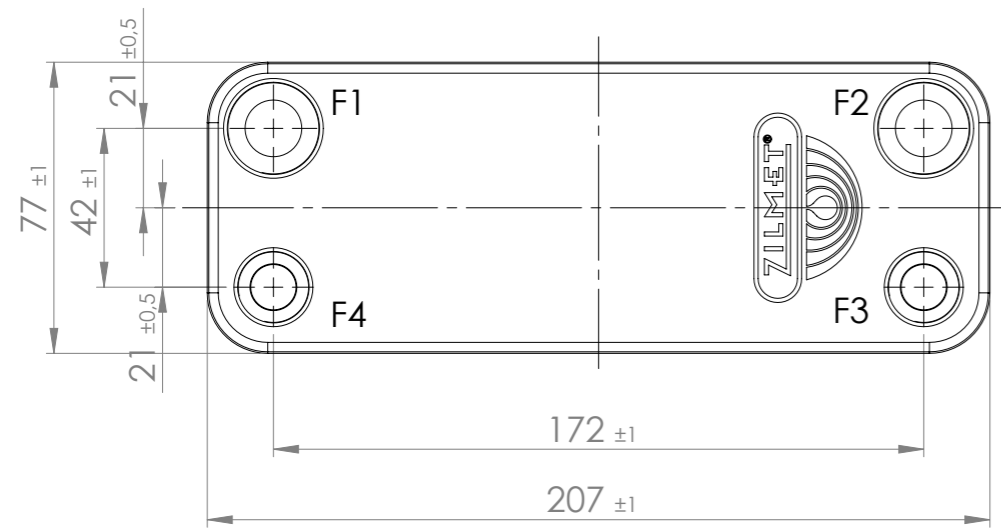

Press.max eserc. circ. primario (Max oper. press. primary circuit): 3 bar
 Press.max eserc. circ. second. (Max oper. press. second. circuit): 8 bar
 Temperatura esercizio (Max oper. temperature): -10/+120 °C
 Materiale piastre corr. (Shaped plates material): INOX AISI 316L
 Materiale di brasatura (Brazing material): 99.9% Cu
 Materiale raccordi (Connection material): INOX AISI 316 1/2"G
 FE37 3/4"G

CIRCOLAZIONE FLUIDI CIRCUITO PRIMARIO F1 - F2 (PRIMARY CIRCUIT F1 - F2)
 CIRCUITO SECONDARIO F3 - F4 (SECONDARY CIRCUIT SANITARY F3 - F4)

DRAWING FOR APPROVAL
 PLEASE RETURN THIS DRAWING WITH
 YOUR COMPANY STAMP, SIGNATURE AND
 DATE. AFTER YOUR APPROVAL WE WILL
 BE PROCEEDING WITH SUPPLIES AND
 PRODUCTION.

Revisioni		Revisions	
Rev.	Descrizione	Rev.	Data
03	REDESIGNED WITH S.W.		16/09/2015
04	Rotated the logo; F1, F2, F3, F4		29/08/2018

Zilmet S.p.a. Via del Santo,242 35010 Limena (PD)-ITALY Tel. +39 049 7664901 Fax +39 049 767321 www.zilmet.com zilmet@zilmet.it	DRAWING N° ZB 207	SCALE 1:2	MATERIAL SEE TABLE
	DENOMINATION BRAZED HEAT EXCHANGER	CODE 17B207--02	This drawing is the property of company Zilmet S.p.a. All rights reserved.

DRAWN GIBIN G.	DATE 29/08/2018	Signature
CHECKED PIROVANO M.	DATE 29/08/2018	Signature
APPROVED Sig.ri BENETTOLO	DATE 29/08/2018	Signature